

Kurianova Irina Vladimirovna,
Ph.D., Associate Professor of the Department of Finance and Credit,
Institute of Economics and Management,
V.I. Vernadsky Crimean Federal University,
Simferopol, Russian Federation.

THE ROLE OF CREDIT INSTITUTIONS IN THE FIGHT AGAINST MONEY LAUNDERING AND THE FINANCING OF TERRORISM

The article examines the mechanisms of measures taken by banks aimed at combating the laundering of proceeds from crime and the financing of terrorism. The essential cycle of using «dirty» money in the economy is revealed. The main anti-money laundering tools used in the bank in three main areas are systematized and described: direct financial monitoring, employee training and interaction with external institutions. It is concluded that the system for preventing and combating money laundering in a bank is a set of bank tools aimed at identifying and assessing the risk of its clients at the stage of establishing relationships, as well as monitoring the client's operations at the stage of his cooperation with the bank.

Key words: money laundering, terrorist financing, criminal proceeds, countermeasures.

/ -

, , , . , , -
 , , , : , , -
 , , , , -
 . . [7], . . [1], . . [9], . . [2], . . [2], . . [8], -
 . . [6], . . [10] . -
 . . [3], . . [4], . . [5], . . , . . [11] . -
 , , , - , -
 - , - ; , ; -
 , , , , [1; 7; 10]. -
 . . , « » , -
 , , , -
 • () : ; , -
 • () : , -
 • (,) : , -
 , , , , , -
 , , , , , -
 , , , , , -
 , , , , , -
 , , , , , -

XIX

-
-
-
- 1.

2.

IT-

IT-

« »

1,

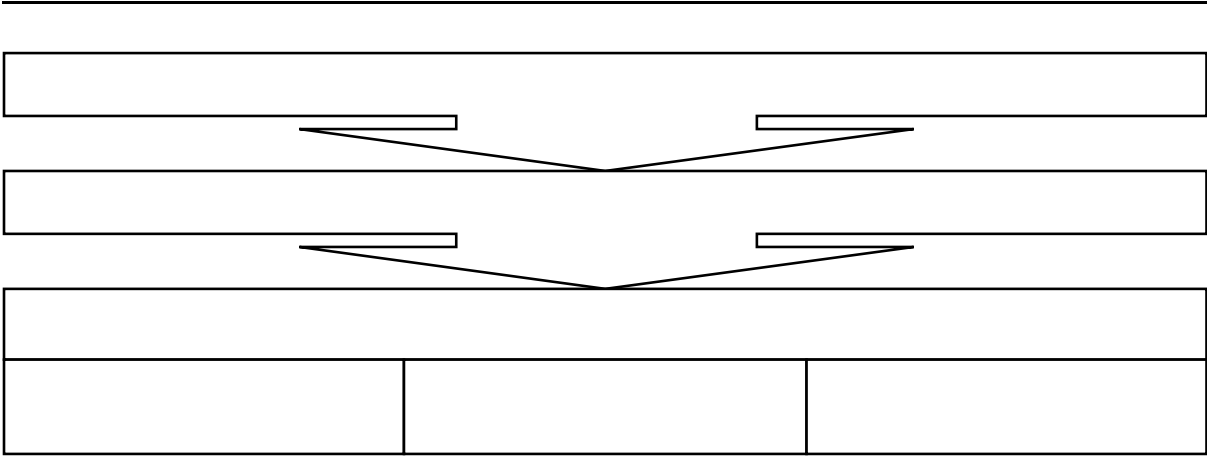

.1. « » ()

, , : — — « »

[1, 7].

« »,

[8].

, , , , , -

,

. , , , , -

, , : :

(, ,)

, , , , -

, , , , -

[1].

, , , , -

, , , (, , -

), (, , -

, (, , -

, (, , -

(, ,)

« », , , ,

2.

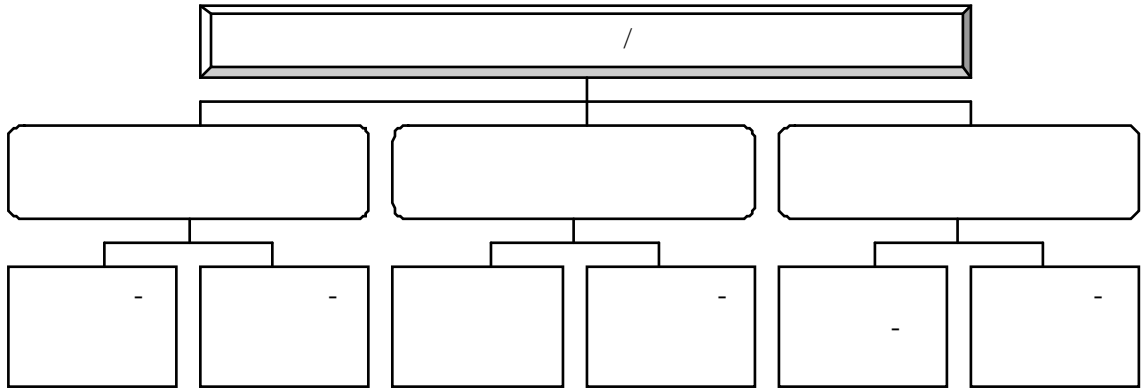

.2.

()

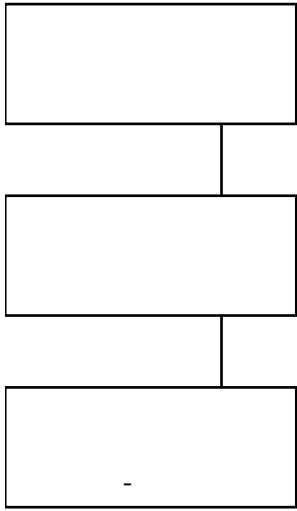

[]

- [] , . . « »

[]

[]

- []

[]

.3.

()

, , -
 .
 , , , , , , , -
 , , , , , , , , , , , -
 , , , , , , , , , , , -
 , , , , , , , , , , , -
 , , , , , , , , , , , -
 , , , , , , , , , , , -
 , , , , , , , , , , , -
 , , , , , , , , , , , -
 , , , , , , , , , , , -
 , , , , , , , , , , , -
 , , , , , , , , , , , -
 , , , , , , , , , , , -
 , , , , , , , , , , , -
 , , , , , , , , , , , -
 , , , , , , , , , , , -
 , , , , , , , , , , , -

- /
- », «
- » . . .
1. / . . . // . — 2017. — .12. 3. — .89-96.
2. . . . // . — 2022. — 3 (37). — URL: cyberleninka.ru/article/n/voprosy-protivodeystviya-finansirovaniya-terrorizma-v-rossiyskoy-federatsii (: 05.06.2024).
3. . . . // . — 2018. — 1. — .193-202.
4. . . . : . — 2022. — 1 (58). — .5-17.
5. . . . // . — 2021. — 1 (54). — .5-15.
6. . . . / . . . ; . . . — ., 2013.
7. . . . : . — 2016. — .12. 5. — .4-17.
8. . . . : . — 2013. — 9 (136). — URL: cyberleninka.ru/article/n/finansirovanie-terrorizma-kanaly-formy-metody-i-istochniki (: 06.06.2024).
9. . . . // . — 2022. — 1. — .213-215.
10. . . . / . . . // . — 2022. — 1 (35). — URL: cyberleninka.ru/article/n/aktualnye-voprosy-protivodeystviya-legalizatsii-prestupnyh-dohodov-finansirovaniyu-terrorizma-i-rasprostraneniyu-oruzhiya-massovogo (: 10.06.2024).
11. . . . / . . . // . — 2022. — 11. — URL: cyberleninka.ru/article/n/osobennosti-finansirovaniya-ekstremizma-i-terrorizma (: 11.06.2024).
12. : 02.07.2021 N 400 // « » — URL: www.consultant.ru/document/cons_doc_LAW_389271/ (: 10.06.2024).
13. : 06.03.2006 35- 3 (. 10.07.2023) // « » — URL: www.consultant.ru/document/cons_doc_LAW_58840/ (: 10.06.2024).
14. () : 07.08.2001 115- (. 10.07.2023) // « » — URL: www.consultant.ru/document/cons_doc_LAW_32834 (: 10.06.2024).

СПИСОК ЛИТЕРАТУРЫ

1. Andrianova, A.I. Protседurnyy instrumentariy finansovogo monitoringa v bankovskoy sfere Rossii / A.I. Andrianova // Teoriya i praktika sudebnoy ekspertizy. — 2017. — T. 12. 3. — S. 89-96.
2. Anufriyeva, K.Yu. Voprosy protivodeystviya finansirovaniya terrorizma v Rossiyskoy Federatsii / K.Yu. Anufriyeva, S.S. Yemanova // Khronoekonomika. — 2022. — 3 (37). — URL: cyberleninka.ru/article/n/voprosy-protivodeystviya-finansirovaniya-terrorizma-v-rossiyskoy-federatsii (data obrashcheniya: 05.06.2024).
3. Bogatyrev, S.I. Obespecheniye ekonomicheskoy bezopasnosti finansovoy sistemy Rossii v usloviyakh razvitiya tenevogo bankinga na osnove tsifrovyykh finansovykh tekhnologiy / S.I. Bogatyrev // Nauchnoye obozreniye. Seriya 1: Ekonomika i pravo. — 2018. — 1. — S. 193-202.

-
4. Borshch, L.M. Finansovaya bezopasnost' rossiyskoy finansovoy sistemy: sovremennyye vyzovy i ugrozy / L. M. Borshch // Nauchnyy vestnik: finansy, banki, investitsii. — 2022. — 1 (58). — S. 5-17.
5. Vorobyova, E.I. Finansovaya bezopasnost' natsional'noy ekonomiki / E.I. Vorobyova, Yu.M. Denenberg // Nauchnyy vestnik: finansy, banki, investitsii. — 2021. — 1 (54). — S. 5-15.
6. Yegorov, D. A. Ispol'zovaniye sovremennykh metodov vovlecheniya lits v terroristicheskuyu deyatel'nost': analiticheskiy obzor / D. A. Yegorov, T. A. Goncharova, A. Ye. Bondarenko, S. E. Oganesyany; pod obshch. red. A. P. Novikova. — M., 2013.
7. Yedronova, V.N. Razvitiye sistemy finansovogo monitoringa v Rossiyskoy Federatsii / V.N. Yedronova // Natsional'nyye interesy: priority i bezopasnost'. — 2016. — T. 12. — 5. — S. 4-17.
8. Zolotukhin, V.L. Finansirovaniye terrorizma: kanaly, formy, metody i istochniki / V.L. Zolotukhin // Vedomosti UIS. — 2013. — 9 (136). — URL: cyberleninka.ru/article/n/finansirovanie-terrorizma-kanaly-formy-metody-i-istochniki (data obrashcheniya: 06.06.2024).
9. Mashekuasheva, M.KH. Kharakternyye cherty terrorizma kak ideologicheskiye faktory / M.KH. Mashekuasheva, I.K. Animokov // Obrazovaniye i pravo. — 2022. — 1. — S. 213-215.
10. Pisarenko, A. P. Aktual'nyye voprosy protivodeystviya legalizatsii prestupnykh dokhodov, finansirovaniyu terrorizma i rasprostraneniya oruzhiya massovogo unichtozheniya / A. P. Pisarenko // Vestnik TIUE. — 2022. — 1 (35). — URL: cyberleninka.ru/article/n/aktualnye-voprosy-protivodeystviya-legalizatsii-prestupnyh-dohodov-finansirovaniyu-terrorizma-i-rasprostraneniya-oruzhiya-massovogo (data obrashcheniya: 10.06.2024).
11. Fakov, A.M. Osobennosti finansirovaniya ekstremizma i terrorizma / A.M. Fakov // Pravo i upravleniye. — 2022. — 11. — URL: cyberleninka.ru/article/n/osobennosti-finansirovaniya-ekstremizma-i-terrorizma (data obrashcheniya: 11.06.2024).
12. O Strategii natsional'noy bezopasnosti Rossiyskoy Federatsii: Ukaz Prezidenta RF ot 02.07.2021 N 400 // SPS «Konsul'tantPlyus». — URL: www.consultant.ru/document/cons_doc_LAW_389271/ (data obrashcheniya: 10.06.2024).
13. O protivodeystvii terrorizmu: Federal'nyy zakon ot 06.03.2006 35-F3 (red. ot 10.07.2023) // SPS «Konsul'tantPlyus» — URL: www.consultant.ru/document/cons_doc_LAW_58840/ (data obrashcheniya: 10.06.2024).
14. O protivodeystvii legalizatsii (otmyvaniyu) dokhodov, poluchennykh prestupnym putem, i finansirovaniyu terrorizma: Federal'nyy zakon ot 07.08.2001 115-FZ (red. ot 10.07.2023) // SPS «Konsul'tantPlyus» — URL: www.consultant.ru/document/cons_doc_LAW_32834 (data obrashcheniya: 10.06.2024).

16 2024

5 2024