336.1

Blazhevich Oleg Georgievich,
Ph.D. in Economics, Associate Professor,
Associate Professor of the Department of Finance and Credit,
Institute of Economics and Management,
V.I. Vernadsky Crimean Federal University,
Simferopol, Russian Federation.
Safonova Natalia Sergeevna,
Master of Finance,
Specialist,
Department of Risk Management,
RNCB Bank (PJSC),
Simferopol, Russian Federation.

THE ESSENCE OF THE STATE BUDGET AND THE METHODOLOGY FOR ASSESSING THE FORMATION OF ITS REVENUE PART

In the modern realities of the development of the state and its economy, it is especially important to pay attention to the issues of effective formation of the revenue side of budgets. Since it is the quality of the generated revenues, as well as their sufficient quantity, that determines how timely and in full the state programs planned for a particular period of time will be

implemented. In addition, it is important to emphasize that today there is no unified methodology for analyzing the revenue side of the state budget in the economic literature, which complicates the process of evaluating the effectiveness of its formation. In this regard, the issues of clarifying the essence of the concept under study, as well as the development of an assessment mechanism and a methodology for analyzing the revenue side of state budgets are quite relevant today.

The article examines the essence of the state budget, as well as the structure of the budget system of the Russian Federation. The definition of the essence of federal budget revenues and its components is given. The authors propose a mechanism for assessing the revenue side of the state budgets, which includes the author's methodology for analyzing the object of research.

Keywords: state budget, federal budget, consolidated budget of the Russian Federation and state extra-budgetary funds, tax activity, budget revenues.

1

« », ,

I.

« »

*

()		
1	2	3
.	« — , (), » [1].	- , - , - .
..	« — , , » [2]	- , - , - , - .
.. ..	« — , » [3].	- , - , - .
..	« — , , » [4].	- , - .
..	« — , , » [5].	- , - , - .
..	« — , () » [6, .44].	- , - , - .

1	2	3
<p>.. -</p> <p>.. -</p>	<p>« —</p> <p>,</p> <p>—</p> <p>,</p> <p>,</p> <p>,</p> <p>,</p> <p>» [7, . 150].</p>	<p>,</p> <p>-</p> <p>,</p> <p>,</p> <p>-</p> <p>.</p>
<p>..</p> <p>..</p>	<p>« —</p> <p>,</p> <p>-</p> <p>» [8, . 7].</p>	<p>-</p> <p>,</p> <p>-</p> <p>-</p> <p>.</p>
<p>..</p>	<p>« —</p> <p>,</p> <p>,</p> <p>-</p> <p>» [9, . 234].</p>	<p>-</p> <p>,</p> <p>-</p> <p>-</p> <p>,</p> <p>-</p> <p>.</p>
<p>..</p>	<p>« —</p> <p>,</p> <p>» [10].</p>	<p>.</p>
<p>..</p>	<p>« —</p> <p>,</p> <p>» [11].</p>	<p>,</p> <p>,</p> <p>-</p> <p>,</p> <p>.</p>
<p>..</p>	<p>« —</p> <p>,</p> <p>» [12, . 8].</p>	<p>,</p> <p>-</p> <p>.</p>
<p>..</p>	<p>« —</p> <p>,</p> <p>,</p> <p>» [13, . 15].</p>	<p>,</p> <p>,</p> <p>-</p> <p>-</p> <p>.</p>
<p>-</p>	<p>« —</p> <p>,</p> <p>» [14, . 6].</p>	<p>,</p> <p>-</p> <p>.</p>

*

... ..

», «
 ()», «
 ()», «
 », «
 ». «
 «
 »:
 », «
 », «
 1
 », «
 »[15].

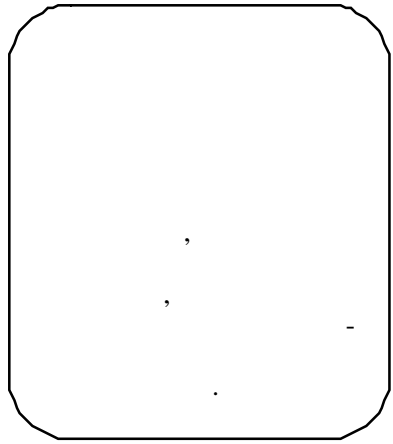
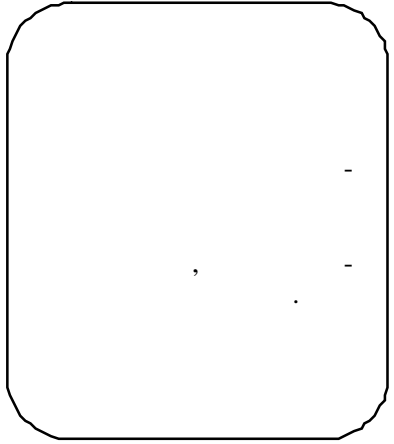
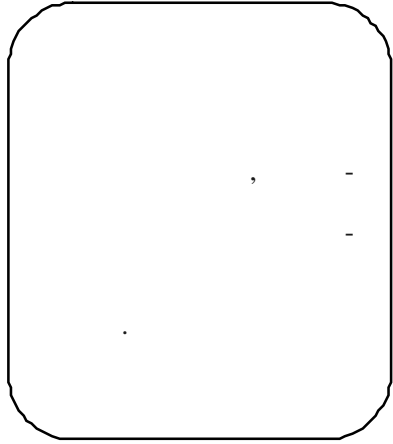
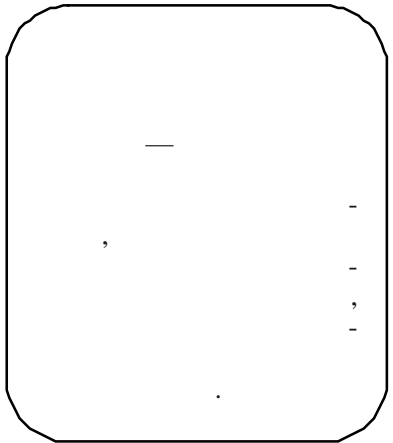
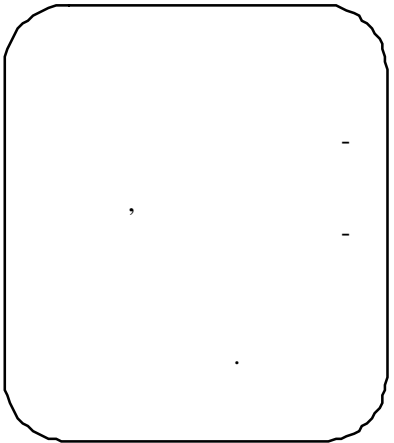
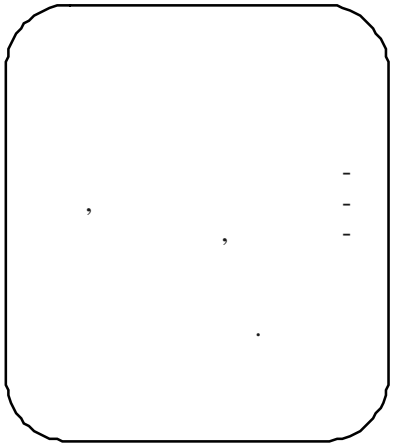

.1. « () »

1.
 2.
 2,
 », «
 », «
 ()
 9

2.

»*

	-	-	-	-	-	-
.			+	+		
..	+	+	+	+	+	
..		+				+
..				+		
..	+				+	+
..					+	
.. -	+	+			+	+
..	+			+		+
..	+	+			+	+
..						+
..				+	+	
..			+	+		
..				+	+	
-	+					

*

01.01.2023 .

»[14].

2

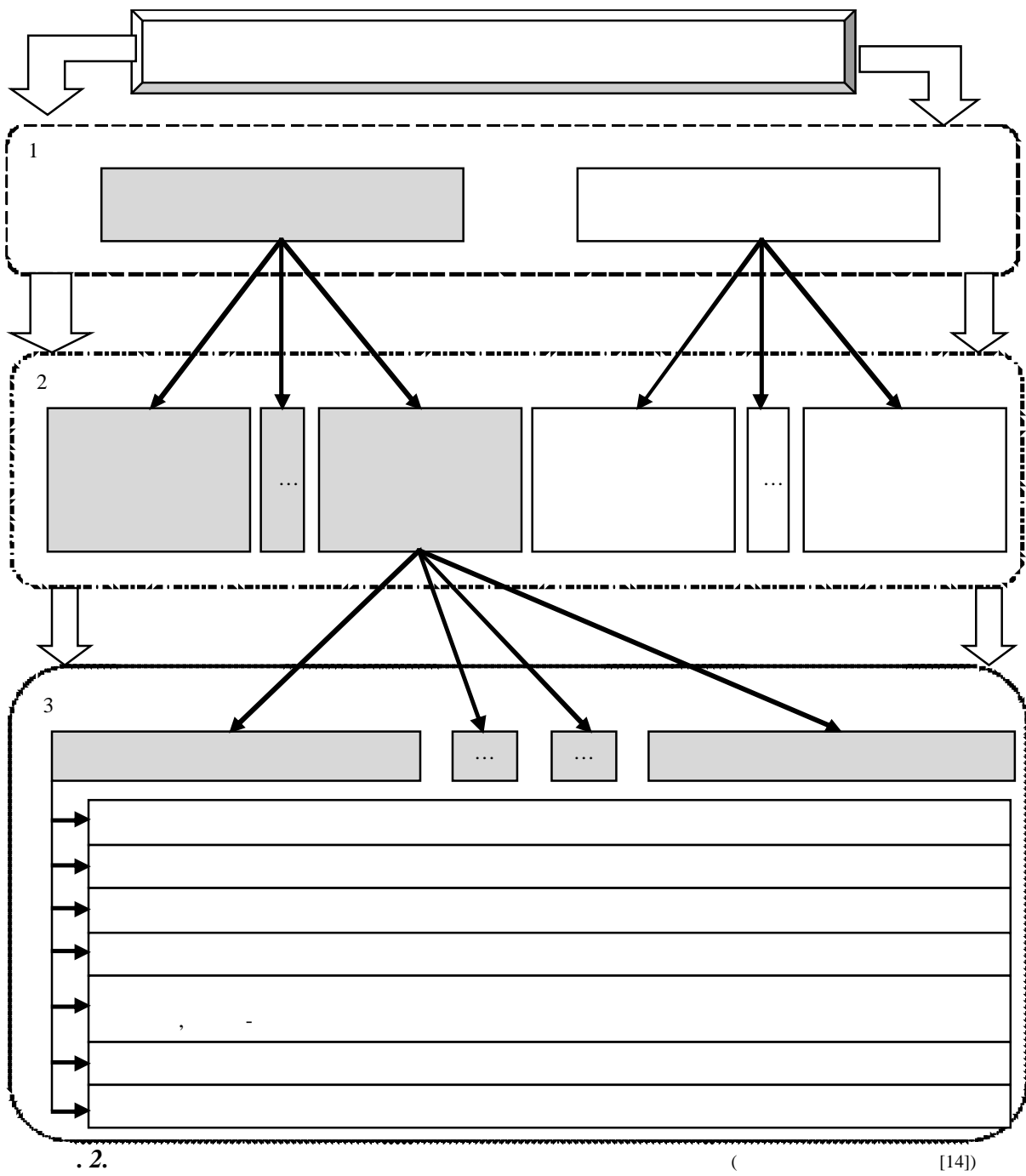

» [17, .374].
 .166.1

... .6
 ,« — , ,
 » [14]. 3.

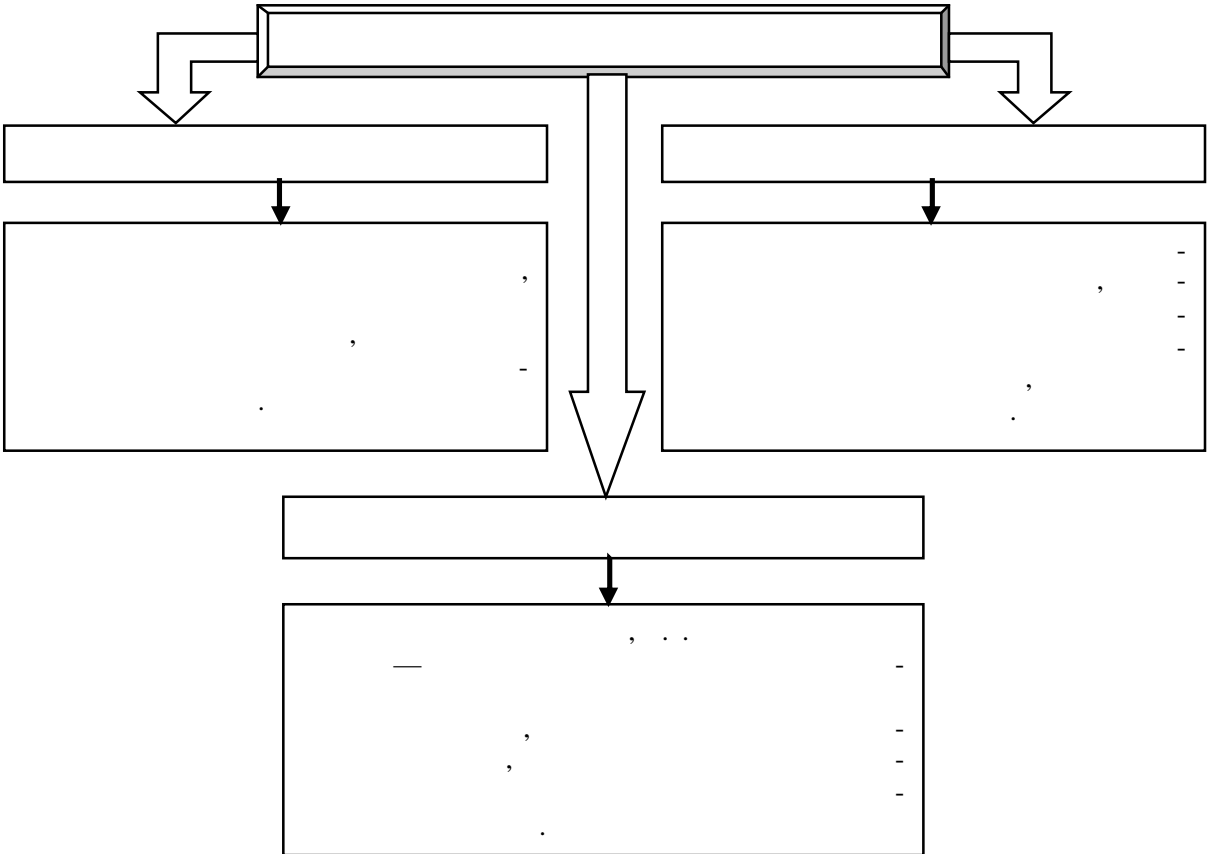

. 3. ([18, 19])

[20].

5

4.

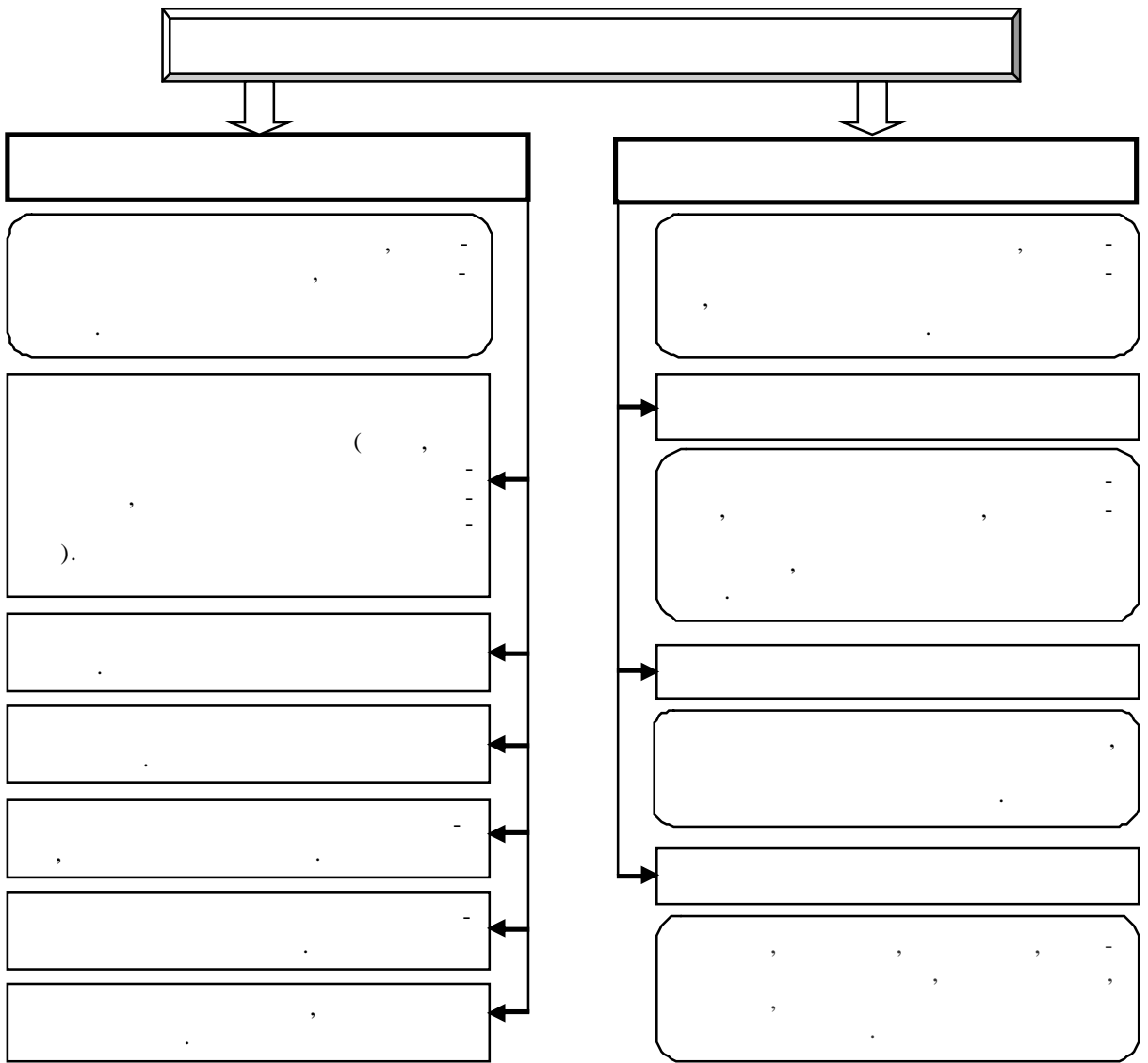

.4.
19, 21])

([14,

(.6).

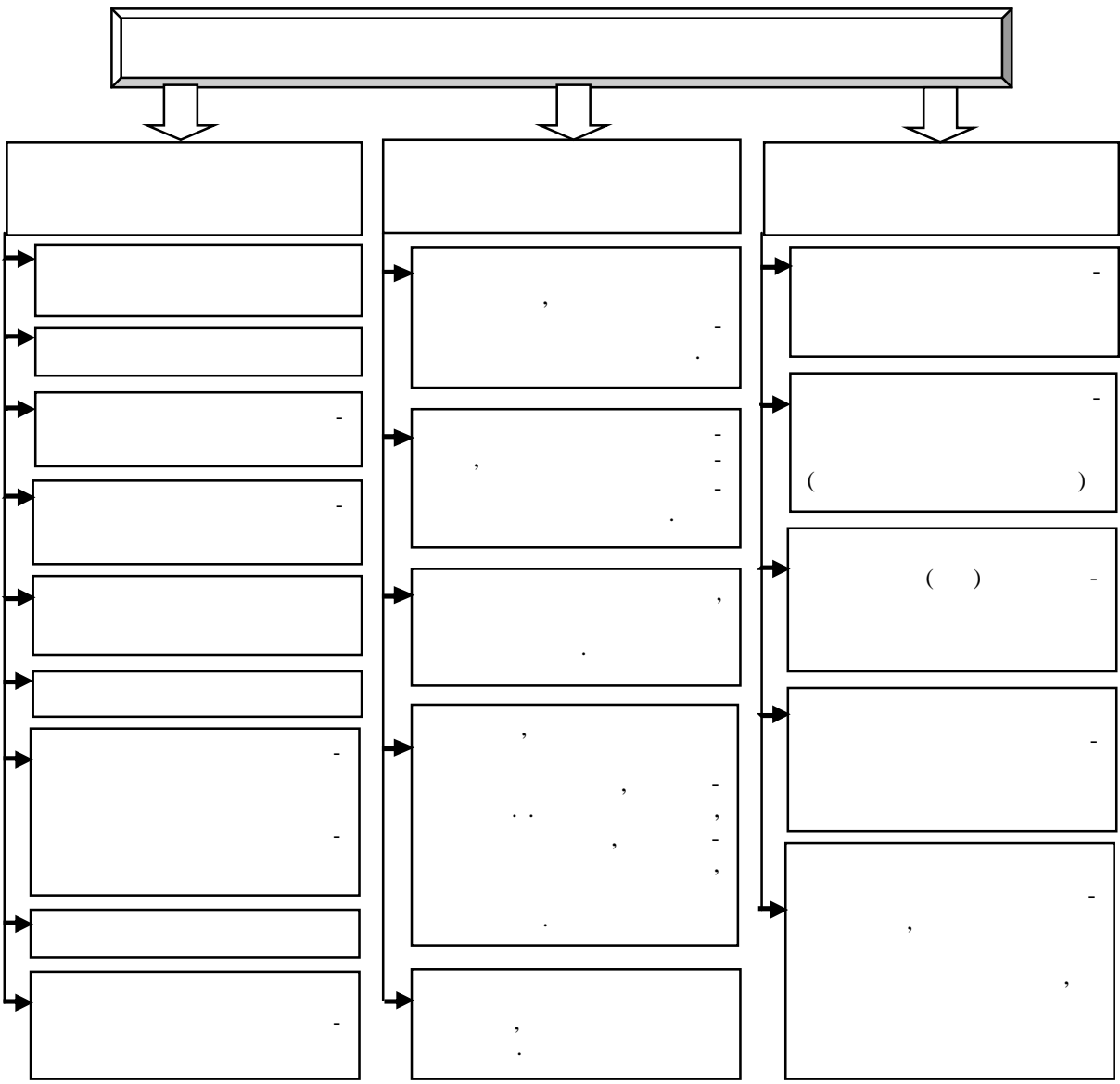

.5.

[14, 19, 21]

(-

7
8

1					
	<table border="1" style="width: 100%;"> <tr><td style="width: 50px; height: 15px;"></td></tr> <tr><td style="width: 50px; height: 15px;"></td></tr> </table>				
2					
	<table border="1" style="width: 100%;"> <tr><td style="width: 50px; height: 15px;"></td></tr> <tr><td style="width: 50px; height: 15px;"></td></tr> </table>				
3					
	<table border="1" style="width: 100%;"> <tr><td style="width: 50px; height: 15px;"></td></tr> <tr><td style="width: 50px; height: 15px;"></td></tr> <tr><td style="width: 50px; height: 15px;"></td></tr> <tr><td style="width: 50px; height: 15px;"></td></tr> </table>				
4					
5					
6					

. 6.

()

8,

,

(

(,),

;

).

«

»

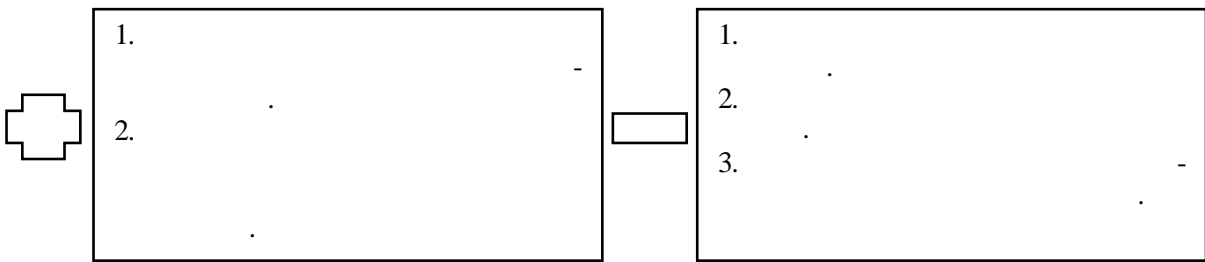
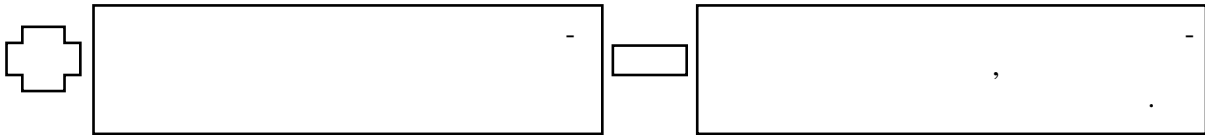
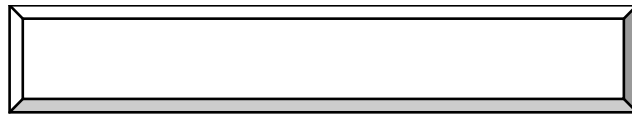

.7. ([22])

«

» [23, .7].

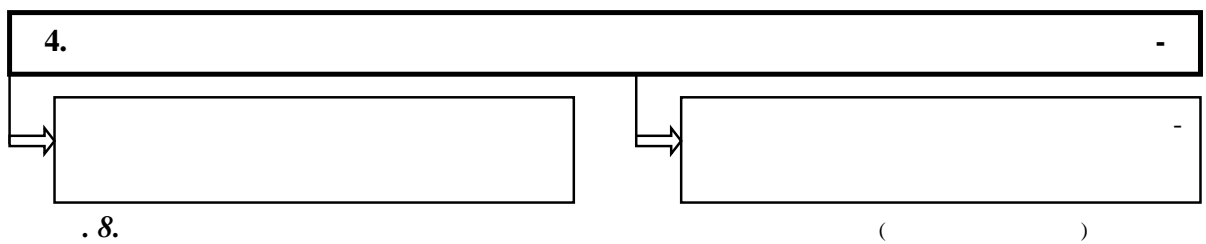
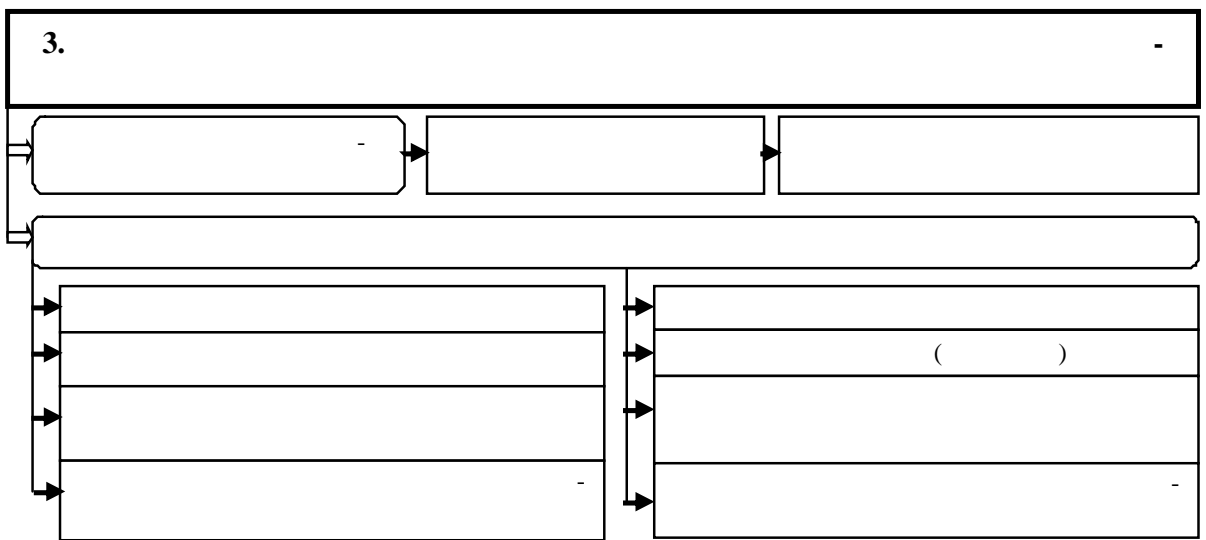
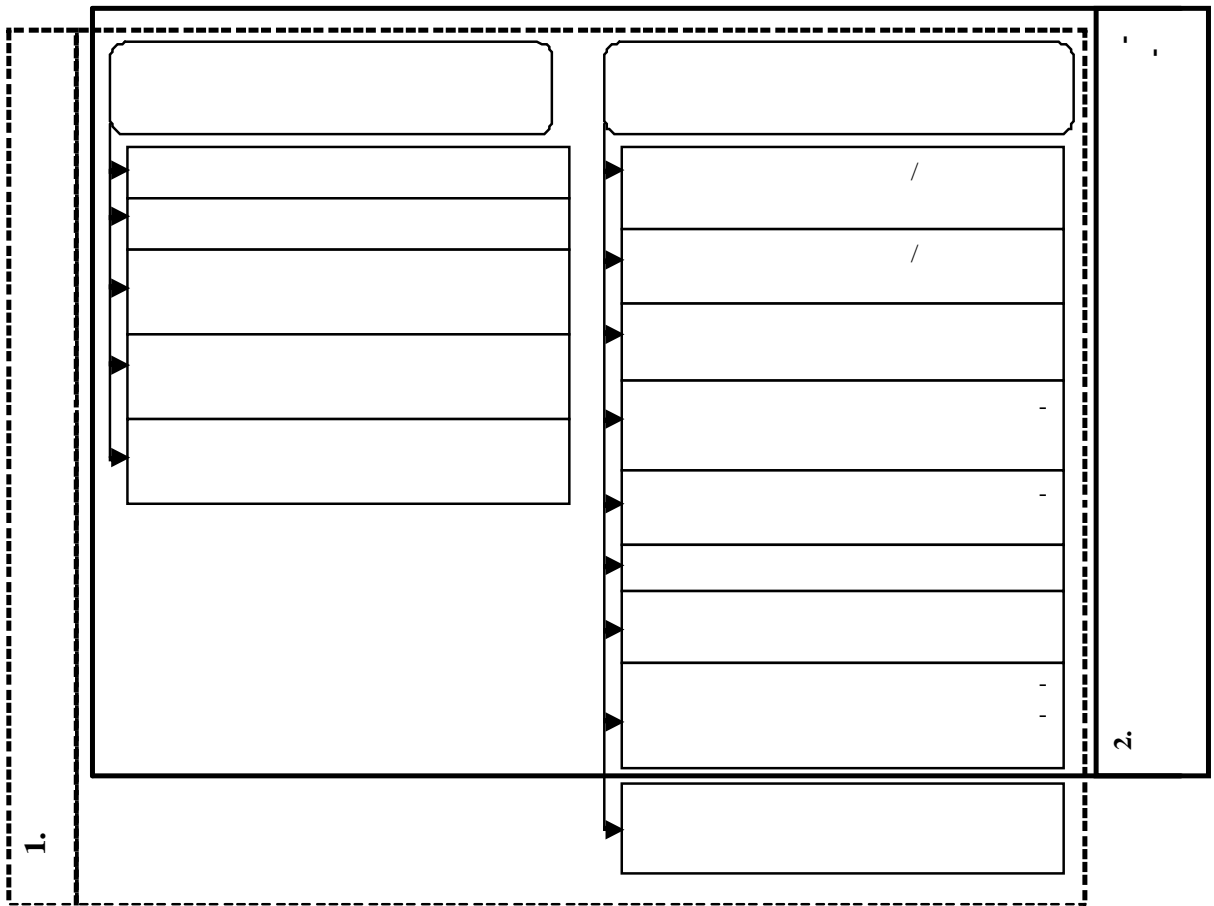

$$\left(\frac{\text{New Value}}{\text{Old Value}} - 1 \right) \times 100\%$$

[1% -- 3%],

$$\left(\frac{\text{New Value}}{\text{Old Value}} + 1 \right) \times 100\%$$

[-10% -- 10%],

$$\left(\frac{\text{New Value}}{\text{Old Value}} - 1 \right) \times 100\%$$

[97% -- 103%],

$$\left(\frac{\text{New Value}}{\text{Old Value}} + 1 \right) \times 100\%$$

35%,

$$\left(\frac{\text{New Value}}{\text{Old Value}} - 1 \right) \times 100\%$$

$$\left(\frac{\text{New Value}}{\text{Old Value}} + 1 \right) \times 100\%$$

$$\left(\frac{\text{New Value}}{\text{Old Value}} - 1 \right) \times 100\%$$

$$\left(\frac{\text{New Value}}{\text{Old Value}} + 1 \right) \times 100\%$$

$$\left(\frac{\text{New Value}}{\text{Old Value}} - 1 \right) \times 100\%$$

[0% -- 20%],

.9.

()

1. Cleveland F.A. Evolution of the Budget Idea in the United States / Frederick A. Cleveland // The Annals of the American Academy of Political and Social Science. — 1915. — 1 November. — Volume 62. — Access Mode: archive.org/details/jstor-1013126 (date of the application: 15.06.2023).

2. . . . , 2023. — 374 .
3. // . — 2013. — 3(11). — .38–48. — EDN RUYETP.
4. . . . — 9- — : °, 2010. — 628 . — ISBN 978-5-394-00850-4. — EDN RAYEYF.
5. « — 5- — : , 2020. — 399 .
6. . . . — 2003. — 5. — .42–49. — DOI 10.32609/0042-8736-2003-5-42-49. — EDN PJFKAP.
7. . . . , — 3- — : , 2023. — 523 .
8. . . . : / , 2004. — 201 . — ISBN 5-7253-1010-8. — EDN OWNTBZ.
9. : / , [. . . .]; — : , 1995. — 400 .
10. . . . — 2012. — 27(507). — .64–71. — EDN PAFDQP.
11. . . . [. . . .]: / ; — « ».— : , 2017.—(. . . .)— 590 .
12. . . . : / — , 2000.— 22 .
13. . . . « », 1999.— 224 . — EDN VSPARN.
14. [. . . .]/ — : : www.consultant.ru/document/cons_doc_LAW_19702/ (: 15.06.2023).
15. . . . , — 2016. — 4(37). — .27–33. — EDN YJMOEB.
16. . . . / // — 2015. — 88. — .21–25. — EDN VQYYFT.
17. . . . — 2019. — 5(33). — .373–377. — EDN PWCXLO.
18. . . . (. . . .) / // : — 2018. — 3(34).
19. // : , — 2016. — 4(37). — .19–26. — EDN YJMODR.
20. . . . — 2011. — 3(74). — .110–113. — EDN PWINXX.
21. [. . . .]/ — : : www.consultant.ru/document/cons_doc_LAW_19671/ (: 15.06.2023).
22. . . . // : , — 2021. — 1(54). — .106–124. — DOI 10.37279/2312-5330-2021-1-106-124. — EDN HXNCGG.
23. . . . // : , — 2016. — 2(35). — .5–13. — EDN WEBHEV.
24. . . . [. . . .] // : / — 2015. — 6(200). — .111–116. — EDN UHPPEX.

SPISOK LITERATURY

1. Cleveland F.A. Evolution of the Budget Idea in the United States / Frederick A. Cleveland // The Annals of the American Academy of Political and Social Science. — 1915. — 1 November. — Volume 62. — Access Mode: archive.org/details/jstor-1013126 (date of the application: 15.06.2023).

2. Krokhina Yu.A. Byudzhetnoye pravo Rossii : uchebnik dlya vuzov / Yu.A. Krokhina. — 7-ye izd., pererab. i dop. — Moskva : Izdatel'stvo Yurayt, 2023. — 374 s.
3. Shvetsov, Yu.G. Byudzhet kak finansovaya osnova realizatsii obshchestvennykh proyektov / Yu.G. Shvetsov, O.A. Bulash // Problemy ucheta i finansov. — 2013. — 3(11). — S. 38–48. — EDN RUYETP.
4. Godin, A.M. Byudzhetnaya sistema Rossiyskoy Federatsii : Uchebnik / A.M. Godin, V.P. Goreglyad, I.V. Podporina. — 9-ye izd., ispr. i dop.. — Moskva: Dashkov i K°, 2010. — 628 s. — ISBN 978-5-394-00850-4. — EDN RAYEYF.
5. Gosudarstvennyye i munitsipal'nyye finansy: uchebnik dlya studentov, obuchayushchikhsya po napravleniyam «Gosudarstvennoye i munitsipal'noye upravleniye», «Finansy i kredit» / [G.B. Polyak i dr.]; pod red. G.B. Polyaka, T.Sh. Tinikashvili. — 5-ye izd., pererab. i dop. — M.: YUNITI-DANA, 2020. — 399 s.
6. Bushmin, Ye. Rol' i mesto byudzhetnykh protsedur v sisteme gosudarstvennykh finansov / Ye. Bushmin // Voprosy ekonomiki. — 2003. — 5. — S. 42–49. — DOI 10.32609/0042-8736-2003-5-42-49. — EDN PJFKAP.
7. Finansy, denezhnoye obrashcheniye i kredit : uchebnik dlya vuzov / M. V. Romanovskiy [i dr.]; pod redaktsiyey M.V. Romanovskogo, O.V. Vrublevskoy, N.G. Ivanovoy. — 3-ye izd., pererab. i dop. — Moskva : Izdatel'stvo Yurayt, 2023. — 523 s.
8. Lyapunova, G.V. Byudzhetnaya politika i byudzhetnyy protsess : ucheb. posobiye / G.V. Lyapunova, T.V. Sorokina. — Irkutsk : Baykal'skiy gosudarstvennyy universitet, 2004. — 201 s. — ISBN 5-7253-1010-8. — EDN OWNTBZ.
9. Finansy : ucheb. / V.M. Rodionova, Yu. Ya. Vavilov, L.I. Goncharenko [i dr.]; pod red. V.M. Rodionovoy. — M. : Finansy i statistika, 1995. — 400 s.
10. Shvetsov, Yu.G. Teoreticheskiye aspekty byudzhetnaya kak ekonomicheskoy kategorii / Yu.G. Shvetsov // Finansy i kredit. — 2012. — 27(507). — S. 64–71. — EDN PAFDQP.
11. Komyagin D.L. Byudzhetnoye pravo [Tekst] : uchebnik dlya vuzov / D.L. Komyagin ; Nats. issled. un-t «Vysshaya shkola ekonomiki». — M. : Izd. dom Vysshey shkoly ekonomiki, 2017. — (Uchebniki Vysshey shkoly ekonomiki). — 590 s.
12. Bezhayev O.G. Reformirovaniye mezhbyudzhetnykh otnosheniy : avtoreferat dis. ... kandidata ekonomicheskikh nauk : 08.00.10; Ros. akademiya predprinimatel'stva / O.G. Bezhayev. — Moskva, 2000. — 22 s.
13. Yermilov, V.G. Tolkovyy slovar' sovremennykh byudzhetnykh terminov / V.G. Yermilov. — Tom Vypusk 1. — Moskva : Izdatel'stvo «Dimitreyd Grafik Grup», 1999. — 224 s. — EDN VSPARN.
14. Byudzhetnyy kodeks Rossiyskoy Federatsii [Elektronnyy resurs] / Konsul'tant Plyus. — Rezhim dostupa: www.consultant.ru/document/cons_doc_LAW_19702/ (data obrashcheniya: 15.06.2023).
15. Vorobyova, E.I. Formirovaniye byudzhetnaya regiona: teoriya i praktika / E.I. Vorobyova, Yu.N. Vorobyov // Nauchnyy vestnik: finansy, banki, investitsii. — 2016. — 4(37). — S. 27–33. — EDN YJMOEB.
16. Lominadze, A.A. O ponyatii i roli byudzhetnaya / A.A. Lominadze // Voprosy ekonomiki i prava. — 2015. — 88. — S. 21–25. — EDN VQYYFT.
17. Vermicheva, V.O. Konsolidirovanny byudzhet Rossiyskoy Federatsii / V.O. Vermicheva, T.A. Okincha // Forum molodykh uchenykh. — 2019. — 5(33). — S. 373–377. — EDN PWCXLO.
18. Paul' A.G. O yuridicheskoy prirode zakona (resheniya) o byudzhetnaya / A.G. Paul' // Vestnik VGU. Seriya: Pravo. — 2018. — 3(34).
19. Vorobyova, E.I. Povysheniye effektivnosti federal'nogo byudzhetnaya Rossiyskoy Federatsii / E.I. Vorobyova / Nauchnyy vestnik: finansy, banki, investitsii. — 2016. — 4(37). — S. 19–26. — EDN YJMODR.
20. Malakhatkina, Ye.V. K voprosu o pravovoy prirode nalogov / Ye.V. Malakhatkina // Chelovek: prestupleniye i nakazaniye. — 2011. — 3(74). — S. 110–113. — EDN PWINXX.
21. Nalogovyy kodeks Rossiyskoy Federatsii [Elektronnyy resurs] / Konsul'tant Plyus. — Rezhim dostupa: www.consultant.ru/document/cons_doc_LAW_19671/ (data obrashcheniya: 15.06.2023).
22. Blazhevich, O.G. Osobennosti razvitiya finansovogo rynka v usloviyakh tsifrovizatsii / O.G. Blazhevich, N.S. Safonova // Nauchnyy vestnik: finansy, banki, investitsii. — 2021. — 1(54). — S. 106–124. — DOI 10.37279/2312-5330-2021-1-106-124. — EDN HXNCGG.
23. Metody finansovogo analiza dlya otsenki sostoyaniya predpriyatiy / E.I. Vorobyova, O.G. Blazhevich, N.A. Kirilchuk, N.S. Safonova // Nauchnyy vestnik: finansy, banki, investitsii. — 2016. — 2(35). — S. 5–13. — EDN WEBHEV.
24. Kontseptsiya innovatsionnogo razvitiya Nizhegorodskoy oblasti: sistema analiza i prognozirovaniya / D.N. Lapayev, O.N. Minayeva, Ye.S. Mityakov [i dr.] // Innovatsii. — 2015. — 6(200). — S. 111–116. — EDN UHPPEX.

21 2023

5 2023